Rod End > Spherical Bearings Product Overview

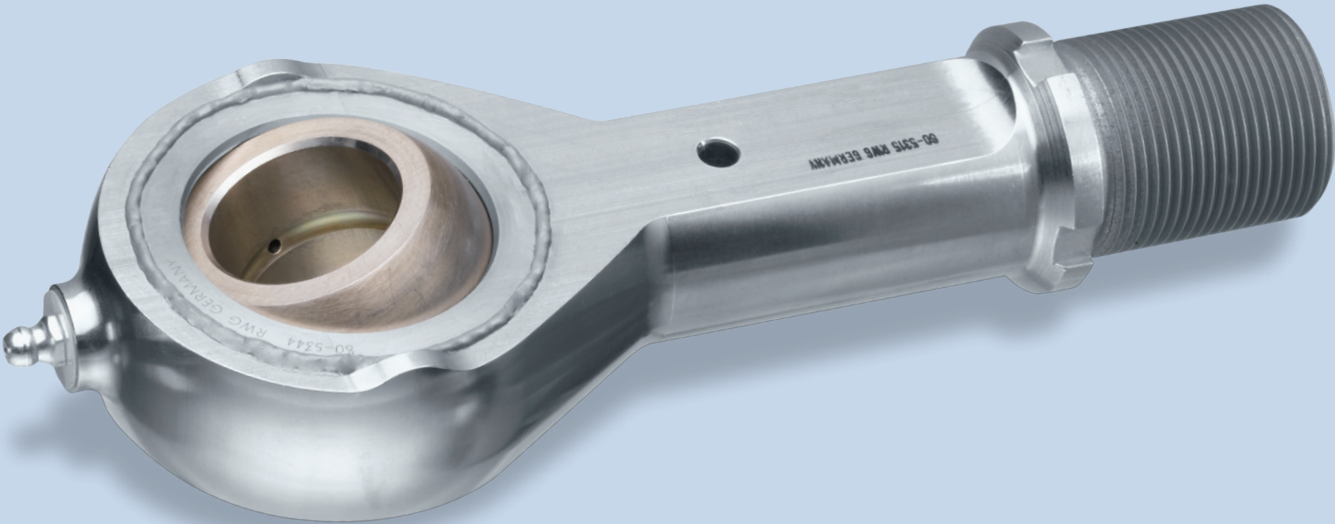
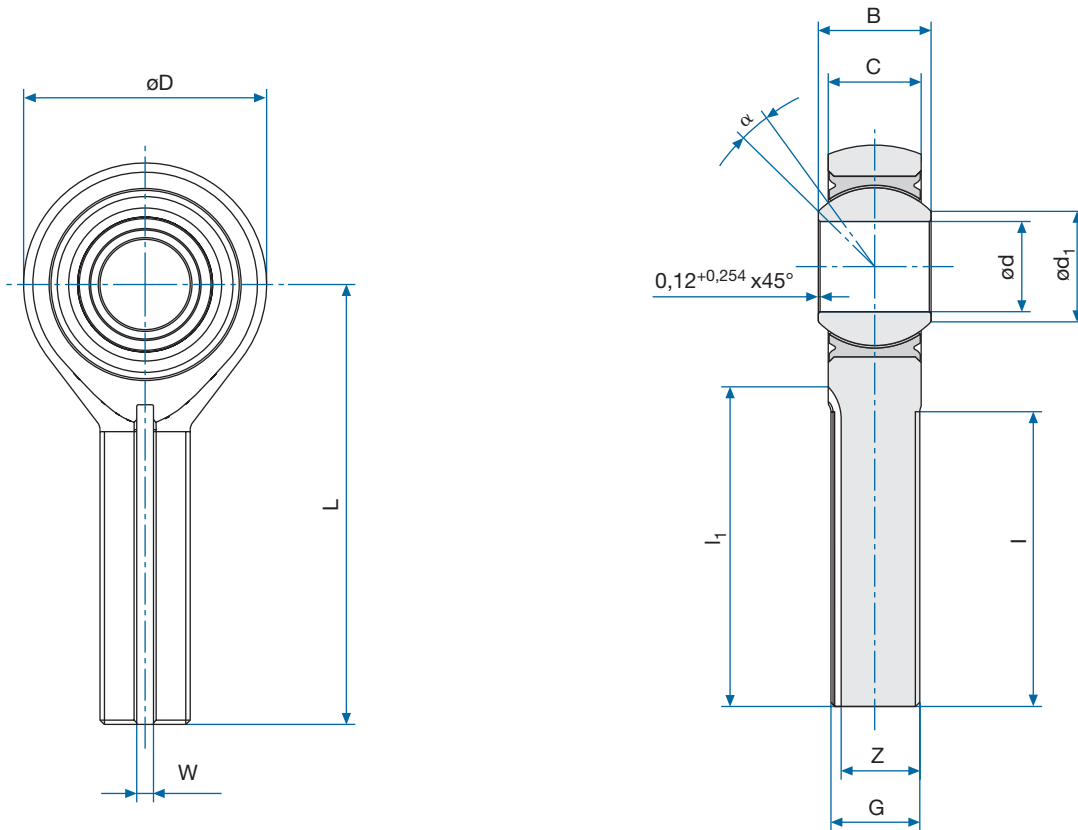

Table of Contents

Page

FMW3E_4 / NSA8143	IV-3-4
FMW3F_4 / NSA8149	IV-5-6
REM	IV-7-8
REF	IV-9-10

Schematic Drawing



Specifications

Diameter Code	d	Δ_{dmp}	D	Δ_{Dmp}	B	Δ_{Bmp}	C	Δ_{Cmp}	d ₁	L	Tol.	I	Tol.
	[mm]	[mm]	[mm]	[mm]	[mm]	[mm]	[mm]	[mm]	[mm]	[mm]	[mm]	[mm]	[mm]
03	4,826	-0,012	20,472	±0,25	11,100	-0,051	8,560	±0,127	7,660	39,675	±0,254	25,400	-0,760 to +1,520
04	6,350	-0,012	20,472	±0,25	11,100	-0,051	8,560	±0,127	7,660	39,675	±0,254	25,400	-0,760 to +1,520
05	7,937	-0,012	22,860	±0,25	11,100	-0,051	8,306	±0,127	10,181	47,625	±0,254	26,975	-0,760 to +1,520
06	9,525	-0,012	26,035	±0,25	12,700	-0,051	10,566	±0,127	11,967	49,225	±0,254	31,750	-0,760 to +1,520
07	11,112	-0,012	29,210	±0,25	14,275	-0,051	11,481	±0,127	13,774	53,975	±0,254	34,925	-0,760 to +1,520
08	12,700	-0,012	33,960	±0,25	15,875	-0,051	13,081	±0,127	15,554	61,925	±0,254	38,100	-0,760 to +1,520
10	15,875	-0,012	38,735	±0,25	19,050	-0,051	14,656	±0,127	19,098	66,675	±0,254	41,275	-0,760 to +1,520
12	19,050	-0,012	45,085	±0,25	22,225	-0,051	16,256	±0,127	22,674	73,025	±0,254	44,450	-0,760 to +1,520
14	22,225	-0,012	51,435	±0,25	22,225	-0,051	19,431	±0,127	26,941	85,725	±0,254	47,625	-0,760 to +1,520
16	25,400	-0,012	70,485	±0,25	34,925	-0,051	25,781	±0,127	32,378	104,775	±0,254	53,975	-0,760 to +1,520

Diameter Code	G UNJF-3A	W	Tol.	Z	Tol.	I ₁	Tol.	α	Starting No Code	Torque Code X	Static Limit Load	Weight
	[in]	[mm]	[mm]	[mm]	[mm]	[mm]	[mm]		[Nm]	[Nm]	[kN]	[g]
03	.3125-24	1,57	+0,127	6,60	-0,127	28,50	-0,760 to +1,520	17°	0,06 to 0,68	0,03 to 0,06	10,50	27,2
04	.3125-24	1,57	+0,127	6,60	-0,127	28,50	-0,760 to +1,520	17°	0,06 to 0,68	0,03 to 0,06	21,62	31
05	.3125-24	1,57	+0,127	6,60	-0,127	30,80	-0,760 to +1,520	14°	0,11 to 1,13	0,03 to 0,06	31,94	50
06	.3750-24	2,36	+0,127	7,90	-0,127	34,30	-0,760 to +1,520	10°	0,11 to 1,13	0,03 to 0,06	38,03	63
07	.4375-20	2,36	+0,127	9,40	-0,127	39,30	-0,760 to +1,520	12°	0,11 to 1,13	0,06 to 0,12	53,38	113
08	.5000-20	2,36	+0,127	11,07	-0,127	42,40	-0,760 to +1,520	9°	0,11 to 1,13	0,06 to 0,12	86,74	128
10	.6250-18	3,175	+0,127	13,74	-0,127	46,00	-0,760 to +1,520	12°	0,11 to 1,13	0,06 to 0,12	97,42	167
12	.7500-16	3,175	+0,127	16,84	-0,127	49,35	-0,760 to +1,520	14°	0,11 to 1,13	0,06 to 0,12	130,33	263
14	.8750-14	3,96	+0,127	19,74	-0,127	53,40	-0,760 to +1,520	7°	0,23 to 1,8	0,11 to 0,22	153,46	358
16	1.2500-12	4,75	+0,127	28,85	-0,127	61,00	-0,760 to +1,520	15°	0,23 to 1,8	0,11 to 0,22	357,19	1043



Designation

NSA8143 -04 X R F P

FMW3E 4-4 X R K

Surface Treatment

- No Code: Non
- P: Rod End Cadmium Plated

Longitudinal Groove

- F: Without Groove
- K: With Groove

Thread

- R: Right Hand
- L: Left Hand

Starting Torque

- X: Reduced
- Non: Normal

Diameter Code

Number of Series

- Rod End: EN2539 / 17-4PH H1025 / 1.4548.4
- Outer Ring: EN2539 / 17-4PH H1150 / 1.4548.4
- Inner Ring: EN2030 / AISI 440C / 1.3544.9
- Liner: per SAE AS81820 / EN2755
- Technical Specification: SAE AS81935

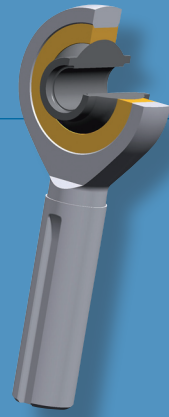

FMW3E_.4

NSA8143

- > Male Thread
- > Self Lubricating
- > CRES

Schematic Drawing

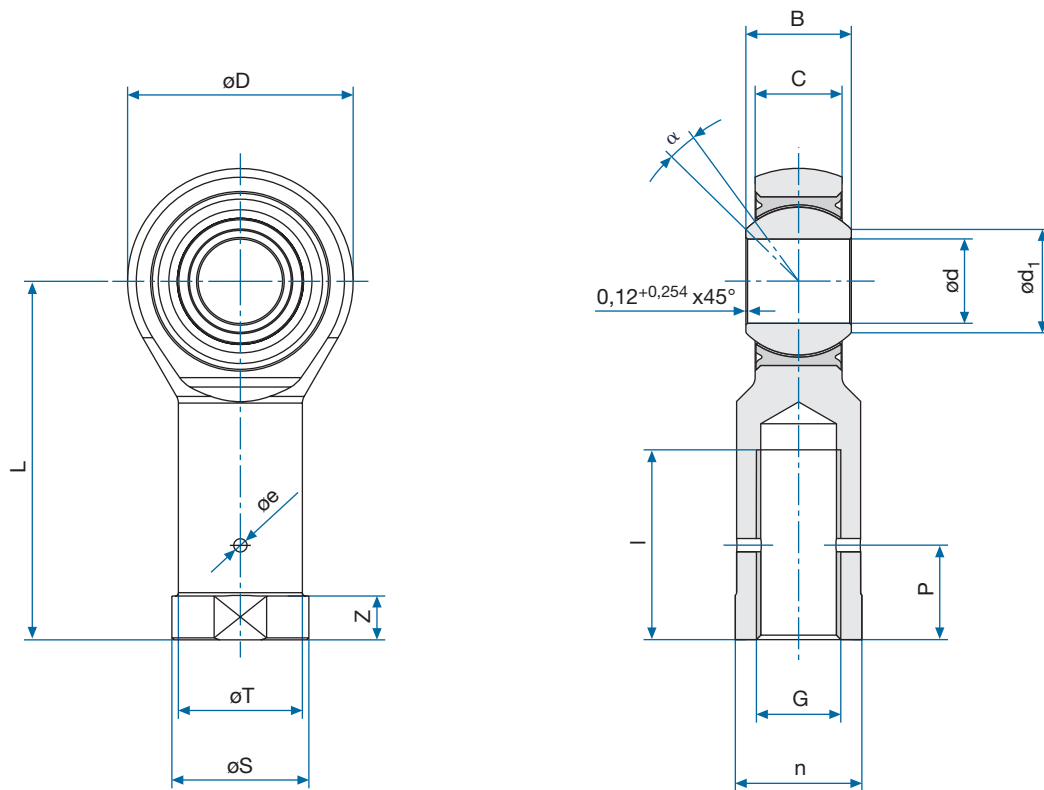

Specifications

Diameter Code	d	Δ_{dmp}	D	Δ_{Dmp}	B	Δ_{Bmp}	C	Δ_{Cmp}	d_1	L $\pm 0,254$	I
	[mm]	[mm]	[mm]	[mm]	[mm]	[mm]	[mm]	[mm]	[mm]	[mm]	[mm]
03	4,826	-0,013	20,472	-0,254 to +0,889	11,100	-0,051	8,560	$\pm 0,127$	7,645	34,925	19,050
04	6,350	-0,013	20,472	-0,254 to +0,889	11,100	-0,051	8,560	$\pm 0,127$	7,645	37,312	19,050
05	7,937	-0,013	22,860	-0,254 to +0,889	11,100	-0,051	8,306	$\pm 0,127$	10,185	34,925	19,050
06	9,525	-0,013	26,035	-0,254 to +0,889	12,700	-0,051	10,566	$\pm 0,127$	11,963	41,275	23,799
07	11,112	-0,013	29,210	-0,254 to +0,889	14,275	-0,051	11,481	$\pm 0,127$	13,767	46,024	26,975
08	12,700	-0,013	33,960	-0,254 to +0,889	15,875	-0,051	13,081	$\pm 0,127$	15,545	53,975	28,575
10	15,875	-0,013	38,738	-0,254 to +0,889	19,050	-0,051	14,656	$\pm 0,127$	19,100	66,675	38,100
12	19,050	-0,013	45,085	-0,254 to +0,889	22,225	-0,051	16,256	$\pm 0,127$	22,675	73,025	41,148
14	22,225	-0,013	51,435	-0,254 to +0,889	22,225	-0,051	19,431	$\pm 0,127$	26,987	85,725	47,625
16	25,400	-0,013	70,485	-0,254 to +0,889	34,925	-0,051	25,781	$\pm 0,127$	32,385	104,775	53,975
20	31,750	-0,013	73,660	-0,254 to +0,889	38,100	-0,051	28,956	$\pm 0,127$	37,075	127,000	79,975

Diameter Code	Tol.	n	S	P	G	T	e	Z	α	Static Limit Load	Weight
	[mm]	$\pm 0,254$	$\pm 0,254$	$\pm 0,381$	UNF-3B	$\pm 0,381$	$\pm 0,10$	$\pm 0,254$		[kN]	[g]
		[mm]	[mm]	[mm]	[in]	[mm]	[mm]	[mm]			
03	-0,762 to +1,524	11,100	12,700	9,652	.3125-24	10,719	2,0	6,350	16°	15,55	27
04	-0,762 to +1,524	11,100	12,700	9,652	.3125-24	10,719	2,0	6,350	16°	15,55	27
05	-0,762 to +1,524	11,100	12,700	9,652	.3125-24	10,719	2,0	6,350	15°	16,40	31
06	-0,762 to +1,524	14,783	15,875	11,176	.3750-24	14,402	2,0	6,350	9°	26,16	49
07	-0,762 to +1,524	15,875	17,449	12,700	.4375-20	15,494	2,0	6,350	11°	33,81	81
08	-0,762 to +1,524	19,050	20,624	14,224	.5000-20	18,669	2,0	6,350	9°	44,48	127
10	-0,762 to +1,524	22,225	25,400	17,526	.6250-18	21,844	2,0	6,350	12°	60,05	190
12	-0,762 to +1,524	25,400	26,924	20,828	.7500-16	25,019	2,0	6,350	13°	80,07	231
14	-0,762 to +1,524	28,575	30,150	23,875	.8750-14	28,194	2,0	6,350	6°	104,53	426
16	-0,762 to +1,524	31,750	33,325	27,178	1.0000-12	31,369	2,0	6,350	12°	192,66	612
20	-0,762 to +1,524	42,900	44,450	33,528	1.2500-12	42,494	2,0	6,350	13°	288,74	1406



Designation

NSA8143 -04 L

FMW3F 5-4 L

Thread

R: Right Hand

L: Left Hand

Diameter Code

Number of Series

Rod End: EN2539 / 17-4PH H1025 / 1.4548.4; Cadmium Plated

Outer Ring: EN2539 / 17-4PH H1150 / 1.4548

Inner Ring: EN2030 / AISI 440C / 1.3544.9

Liner: per SAE AS81820 / EN2755

Technical Specification: SAE AS81935



FMW3F_.4

NSA8149

- > Female Thread
- > Self Lubricating
- > CRES

Schematic Drawing

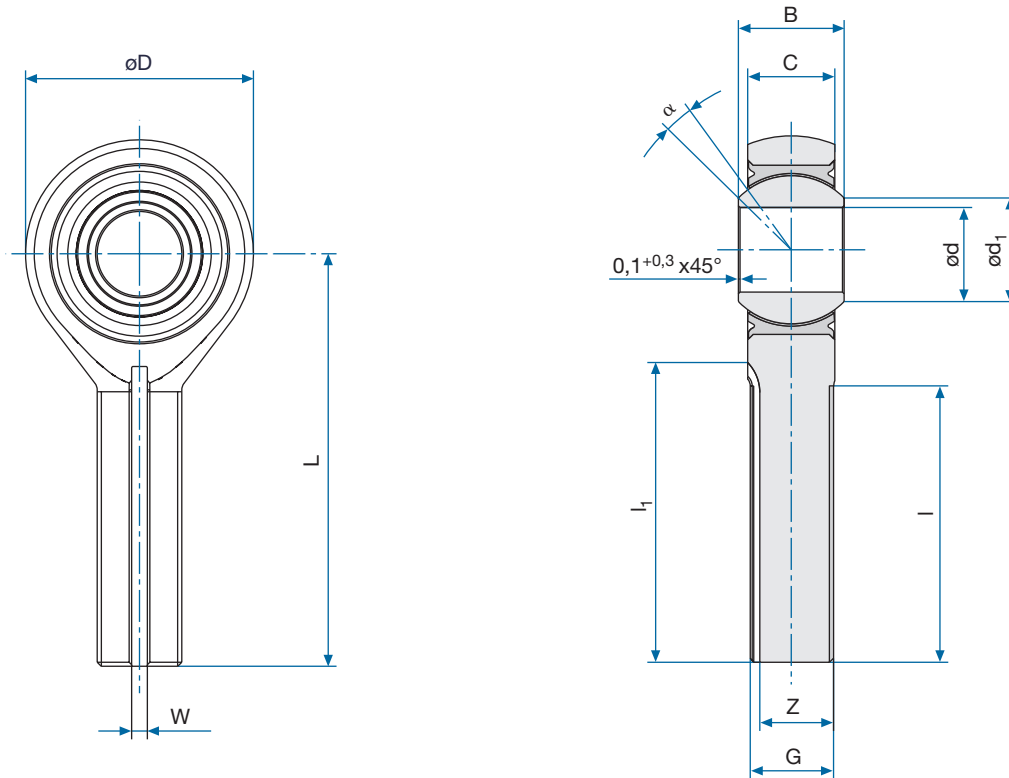

Specifications

Type	d	Δ_{dmp}	D	Δ_{Dmp}	B	Δ_{Bmp}	C	Δ_{Cmp}	d_1	L $\pm 0,254$	I	Tol.
	[mm]	[mm]	[mm]	[mm]	[mm]	[mm]	[mm]	[mm]	[mm]	[mm]	[mm]	[mm]
REM6W10M	4,826	-0,013	20,472	$\pm 0,254$	11,100	-0,051	8,559	$\pm 0,127$	7,66	39,675	24,587	$\pm 0,787$
REM8W10M	6,350	-0,013	20,472	$\pm 0,254$	11,100	-0,051	8,559	$\pm 0,127$	7,66	39,675	24,587	$\pm 0,787$
REM10W10M	7,938	-0,013	22,860	$\pm 0,254$	11,100	-0,051	8,305	$\pm 0,127$	10,181	47,625	30,149	$\pm 0,787$
REM12W10M	9,525	-0,013	26,035	$\pm 0,254$	12,700	-0,051	10,566	$\pm 0,127$	11,967	49,225	30,149	$\pm 0,787$
REM14W10M	11,112	-0,013	29,210	$\pm 0,254$	14,275	-0,051	11,480	$\pm 0,127$	13,774	53,975	32,537	$\pm 0,787$
REM16W10M	12,700	-0,013	33,959	$\pm 0,254$	15,875	-0,051	13,081	$\pm 0,127$	15,554	61,925	37,287	$\pm 0,787$
REM20W10M	15,875	-0,013	38,735	$\pm 0,254$	19,050	-0,051	14,655	$\pm 0,127$	19,098	66,675	39,675	$\pm 0,787$
REM24W10M	19,050	-0,013	45,085	$\pm 0,254$	22,225	-0,051	16,256	$\pm 0,127$	22,674	73,025	42,849	$\pm 0,787$
REM28W10M	22,225	-0,013	51,435	$\pm 0,254$	22,225	-0,051	19,431	$\pm 0,127$	26,941	85,725	50,800	$\pm 0,787$
REM32W10M	25,400	-0,013	70,485	$\pm 0,254$	34,925	-0,051	25,781	$\pm 0,127$	32,378	104,775	59,512	$\pm 0,787$

Type	G UNJF-3A	I_1 -0,51	W +0,10	Z -0,10	α	Starting Normal	Torque Code X	Static Ultimate Load	Fatigue Load	Weight
	[in]	[mm]	[mm]	[mm]		[Nm]	[Nm]	[kN]	[kN]	[g]
REM6W10M	.3125-24	24,892	1,57	6,81	15°	0,05 to 0,68	0,03 to 0,06	10,50	6,50	33
REM8W10M	.3125-24	24,892	1,57	6,81	15°	0,05 to 0,68	0,03 to 0,06	21,60	10,60	33
REM10W10M	.3125-24	32,258	1,57	6,81	14°	0,11 to 1,70	0,03 to 0,06	31,90	12,30	39
REM12W10M	.3750-24	31,369	2,36	8,10	8°	0,11 to 1,70	0,03 to 0,06	38,00	15,90	62
REM14W10M	.4375-20	35,610	2,36	9,73	10°	0,11 to 1,70	0,06 to 0,12	53,40	21,40	83
REM16W10M	.5000-20	40,360	2,36	11,30	9°	0,11 to 1,70	0,06 to 0,12	86,70	34,20	126
REM20W10M	.6250-18	42,748	3,18	13,74	12°	0,11 to 1,70	0,06 to 0,12	97,40	40,80	192
REM24W10M	.7500-16	45,923	3,18	16,84	13°	0,11 to 1,70	0,06 to 0,12	130,30	51,60	290
REM28W10M	.8750-14	53,873	3,96	19,74	6°	0,11 to 2,71	0,11 to 0,22	153,50	58,30	437
REM32W10M	1.2500-12	62,585	4,75	28,86	12°	0,11 to 2,71	0,11 to 0,22	357,20	135,20	1155



Designation

REM S L 8 W 10 M X

Starting Torque

No Code: Normal

X: Reduced

Diameter Code

Thread

No Code: Right Hand

L: Left Hand

Longitudinal Groove

No Code: Without Groove

S: With Groove

Number of Series

Rod End: MIL-S-5000; Cadmium Plated

Outer Ring: EN2539 / 1.4548 / 17-4 PH H1150

Inner Ring: EN2030 / 1.3544.9 / AISI 440C

Liner: per SAE AS81820 / EN2755

Technical Specification: SAE AS81935

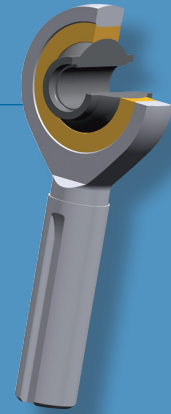

REM

- > Male Thread
- > Self Lubricating
- > Dimensions According to SAE AS81935 / 1

Schematic Drawing

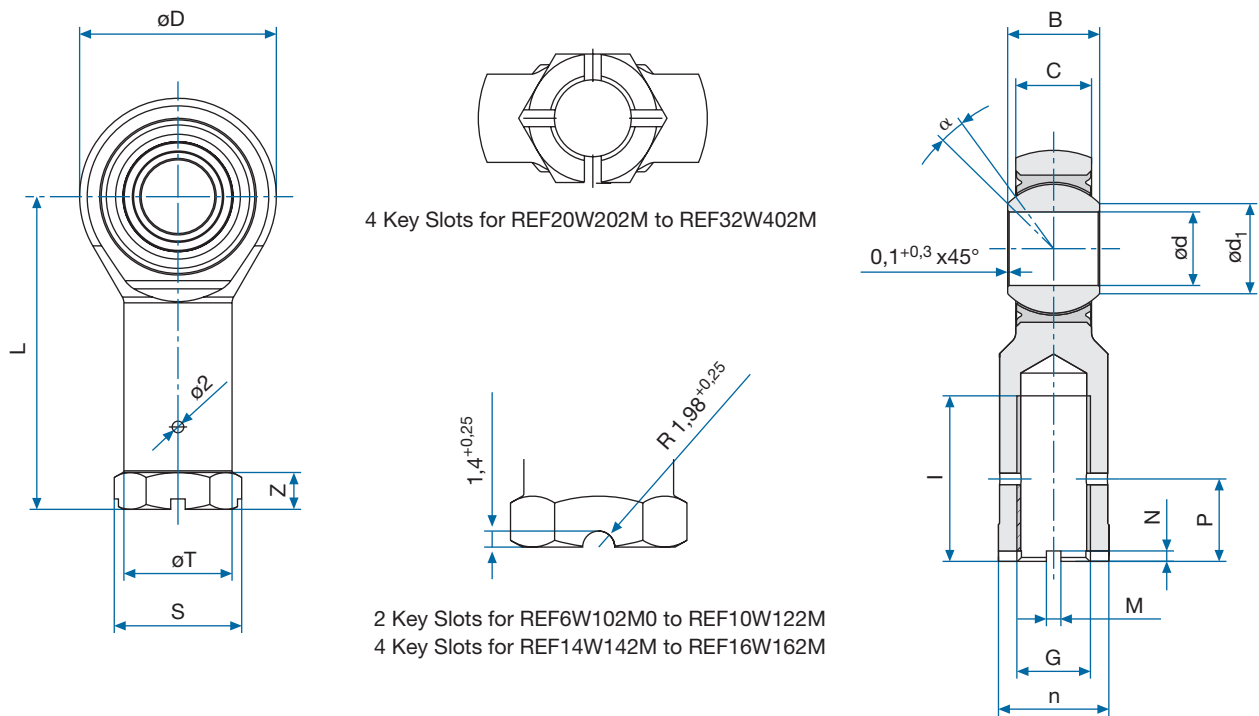

Specifications

Type	d	Δ_{dmp}	D	Δ_{Dmp}	B	Δ_{Bmp}	C	Δ_{Cmp}	d_1	L	I	G
	[mm]	[mm]	[mm]	[mm]	[mm]	[mm]	[mm]	[mm]	[mm]	$\pm 0,254$ [mm]	[mm]	UNJF-3B [in]
REF 6W10M	4,826	-0,013	20,472	$\pm 0,254$	11,100	-0,051	8,559	$\pm 0,127$	7,620	34,925	19,050	.3125-24
REF 8W10M	6,350	-0,013	20,472	$\pm 0,254$	11,100	-0,051	8,559	$\pm 0,127$	7,620	37,312	19,050	.3125-24
REF 10W12M	7,937	-0,013	22,860	$\pm 0,254$	11,100	-0,051	8,305	$\pm 0,127$	9,144	41,275	22,225	.3750-24
REF 12W12M	9,525	-0,013	26,035	$\pm 0,254$	12,700	-0,051	10,566	$\pm 0,127$	11,836	46,024	25,400	.3750-24
REF 14W14M	11,125	-0,013	29,210	$\pm 0,254$	14,274	-0,051	11,480	$\pm 0,127$	13,640	50,800	28,575	.4375-20
REF 16W16M	12,700	-0,013	33,959	$\pm 0,254$	15,875	-0,051	13,081	$\pm 0,127$	15,418	57,150	31,750	.5000-20
REF 20W20M	15,875	-0,013	38,735	$\pm 0,254$	19,050	-0,051	14,655	$\pm 0,127$	18,313	63,500	34,925	.6250-18
REF 24W24M	19,050	-0,013	45,085	$\pm 0,254$	22,225	-0,051	16,256	$\pm 0,127$	21,463	73,025	41,275	.7500-16
REF 28W28M	22,225	-0,013	51,435	$\pm 0,254$	22,225	-0,051	19,431	$\pm 0,127$	25,273	85,725	47,625	.8750-14
REF 32W40M	25,400	-0,013	70,485	$\pm 0,254$	34,925	-0,051	25,781	$\pm 0,127$	32,233	104,775	53,725	1.2500-12

Type	T	S	Z	n	P	M	N	α	Starting Normal Torque	Torque Code X	Static Ultimate Load	Fatigue Load	Weight
	$\pm 0,254$ [mm]	[mm]	-1,574 to $+0,254$ [mm]	-0,254 to $+0,050$ [mm]	$\pm 0,508$ [mm]	$+0,127$ [mm]	$+0,127$ [mm]	[mm]	[Nm]	[Nm]	[kN]	[kN]	[g]
REF 6W10M	10,712	12,700	4,775	11,100	9,525	-	-	15°	0,05 to 0,68	0,03 to 0,06	10,50	6,50	36
REF 8W10M	10,712	12,700	4,775	11,100	9,525	-	-	15°	0,05 to 0,68	0,03 to 0,06	21,60	10,60	38
REF 10W12M	12,319	14,732	6,350	12,700	11,100	-	-	14°	0,11 to 1,70	0,03 to 0,06	31,90	13,40	46
REF 12W12M	13,893	16,764	6,350	14,275	11,100	-	-	8°	0,11 to 1,70	0,03 to 0,06	38,00	15,90	73
REF 14W14M	15,494	18,288	6,350	15,875	12,700	-	-	10°	0,11 to 1,70	0,06 to 0,12	53,40	21,40	96
REF 16W16M	18,669	22,352	6,350	19,050	14,275	-	-	9°	0,11 to 1,70	0,06 to 0,12	86,70	36,70	147
REF 20W20M	21,844	25,908	9,525	22,225	17,475	3,175	1,956	12°	0,11 to 1,70	0,06 to 0,12	97,40	40,80	218
REF 24W24M	25,019	29,464	9,525	25,400	20,625	3,175	1,956	13°	0,11 to 1,70	0,06 to 0,12	130,30	51,60	305
REF 28W28M	28,194	33,020	12,700	28,575	23,800	3,962	2,184	6°	0,11 to 2,71	0,11 to 0,22	153,50	58,30	435
REF 32W40M	42,875	51,308	14,300	44,450	33,325	4,750	2,946	12°	0,11 to 2,71	0,11 to 0,22	357,20	135,20	1232



Designation

REF L 8 W 10 2 M X

Starting Torque

No Code: Normal

X: Reduced

Keyslot

No Code: Without Keyslot

2: With Keyslot

Diameter Code

Thread

No Code: Right Hand

L: Left Hand

Number of Series

Rod End: MIL-S-5000; Cadmium Plated

Outer Ring: EN2539 / 1.4548 / 17-4 PH H1150

Inner Ring: EN2030 / 1.3544.9 / AISI 440C

Liner: per SAE AS81820 / EN2755

Technical Specification: SAE AS81935



REF

- > Female Thread
- > Self Lubricating
- > Dimensions According to SAE AS81935 / 2

Schematic Drawing

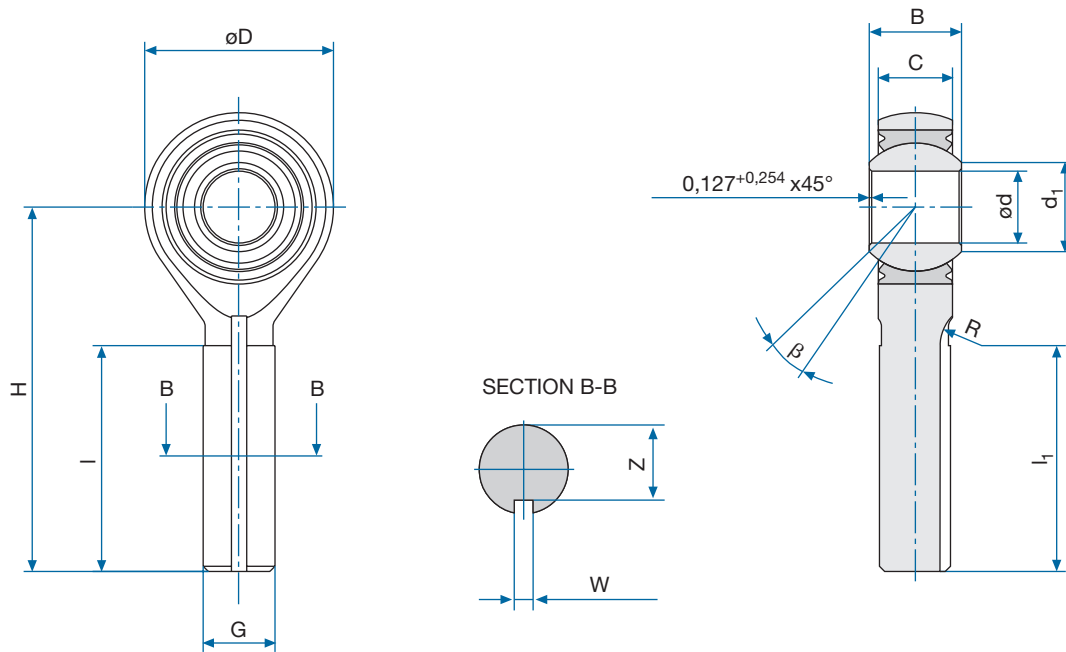

Specifications

Diameter Code	d -0,013 [mm]	D $\pm 0,254$ [mm]	B -0,05 [mm]	C +0,25 [mm]	d ₁ min. [mm]	L $\pm 0,37$ [mm]	H $\pm 0,25$ [mm]	G UNJF-3A [in]	Z -0,127 [mm]	W +0,127 [mm]	R [mm]	I ₁ -0,76 to +1,52 [mm]
03	4,826	20,50	11,10	8,56	7,62	50,74	40,49	.3125-24	6,604	1,575	6,5	25,40
04	6,350	20,50	11,10	8,56	7,62	50,74	40,49	.3125-24	6,604	1,575	6,5	25,40
041	6,350	20,50	11,10	8,56	7,62	62,34	52,09	.3125-24	6,604	1,575	6,5	37,00
05	7,937	22,90	11,10	8,31	9,14	59,08	47,63	.3125-24	6,604	1,575	6,5	26,98
06	9,525	26,00	12,70	10,57	11,84	63,81	50,81	.3750-24	7,900	2,362	6,5	31,75
07	11,113	29,20	14,27	11,48	13,64	70,96	56,36	.4375-20	9,400	2,362	6,5	34,93
071	11,113	29,20	14,27	11,48	13,64	80,8	66,20	.4375-20	9,400	2,362	6,5	34,93
08	12,700	34,00	15,88	13,08	15,42	79,76	62,76	.5000-20	11,074	2,362	6,5	38,10
10	15,875	38,70	19,05	14,67	18,97	87,63	68,28	.6250-18	13,741	3,175	6,5	41,28
12	19,050	45,10	22,23	16,26	21,46	97,18	74,63	.7500-16	16,840	3,175	6,5	44,45
14	22,225	51,40	22,23	19,43	25,27	111,43	85,73	.8750-14	19,735	3,962	8,0	47,63
16	25,400	70,50	34,93	25,78	32,23	140,03	104,78	1.2500-12	28,854	4,750	8,0	53,98

Diameter Code	β	Radial Play normal Code N [mm]	Radial Play reduced Code P [mm]	Axial Play normal Code N [mm]	Axial Play reduced Code P [mm]	Static Radial Limit Load [kN]	Static Axial Limit Load [kN]	Static Ultimate Load [kN]	Fatigue Load [kN]	Weight [g]
03	16,0°	0,01 to 0,03	0,002 to 0,010	0,120 max	0,035 max.	20,0	8,3	30,0	4,7	27
04	16,0°	0,01 to 0,03	0,002 to 0,010	0,120 max	0,035 max.	20,0	8,3	30,0	4,7	27
041	16,0°	0,01 to 0,03	0,002 to 0,010	0,120 max	0,035 max.	20,0	8,3	30,0	4,7	32
05	15,5°	0,01 to 0,03	0,002 to 0,010	0,120 max	0,035 max.	20,0	9,1	30,0	4,9	31
06	9,5°	0,01 to 0,03	0,002 to 0,010	0,120 max	0,035 max.	29,1	12,5	43,6	6,7	50
07	11,0°	0,01 to 0,03	0,002 to 0,010	0,120 max	0,035 max.	31,6	14,4	47,3	8,5	68
071	11,0°	0,01 to 0,03	0,002 to 0,010	0,120 max	0,035 max.	31,6	14,4	47,3	8,5	77
08	9,5°	0,01 to 0,05	0,002 to 0,010	0,229 max.	0,035 max.	56,8	15,4	85,3	13,7	113
10	12,0°	0,01 to 0,05	0,003 to 0,012	0,229 max.	0,040 max.	66,9	18,3	100,4	15,5	168
12	14,0°	0,01 to 0,05	0,004 to 0,015	0,229 max.	0,050 max.	88,8	22,9	133,1	20,4	263
14	6,0°	0,01 to 0,05	0,004 to 0,015	0,229 max.	0,050 max.	102,8	27,1	154,2	23,8	358
16	14,5°	0,01 to 0,05	0,004 to 0,015	0,229 max.	0,050 max.	231,5	35,4	347,3	53,3	1043



Designation

EN6055 R 04 N T A K

Longitudinal Groove

F: Without Groove

K: With Groove

Grease Type

A: NATO G 354 / MIL-PRF-23827

B: NATO G 395 / MIL-PRF-81322

Surface Treatment

T: Passivated

P: Cadmium Plated

Radial Play

N: Normal

R: Reduced

Diameter Code

Thread

R: Right Hand

L: Left Hand

Number of EN Standard

Rod End: EN2539 / 17-4PH H1025 / 1.4548.4

Outer Ring: EN2539 / 17-4PH H1150 / 1.4548

Inner Ring: EN2030 / AISI 440C / 1.3544.9

Technical Specification: EN6099

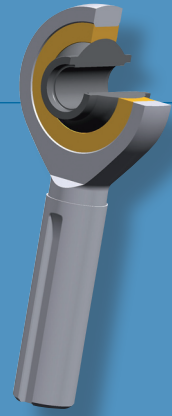

EN6055

- > Male Thread
- > Metal to Metal Bearing
- > CRES

Schematic Drawing

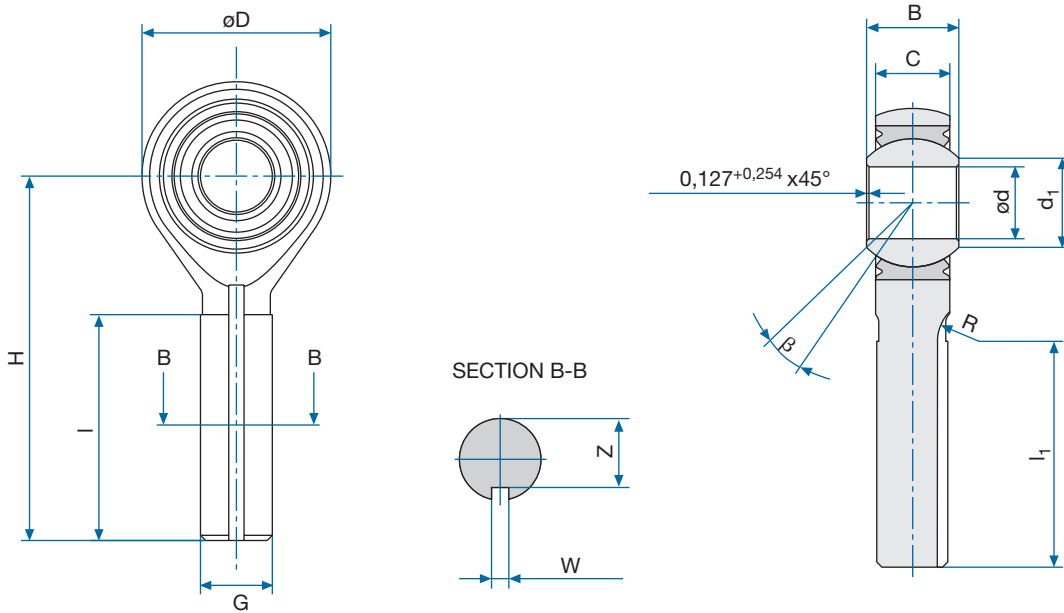

Specifications

Diameter Code	d		D	B	d ₁	H	G	Z	W		I ₁
	-0,013 [mm]	+0,25 [mm]	±0,254 [mm]	-0,05 [mm]	min. [mm]	±0,25 [mm]	UNJF-3A [in]	-0,127 [mm]	+0,127 [mm]	-0,76 to +1,52 [mm]	
03	4,826	8,56	20,47	11,10	7,62	39,68	.3125-24	6,6	1,58	24,59	
04	6,350	8,56	20,47	11,10	7,62	39,68	.3125-24	6,6	1,58	24,59	
041	6,350	8,56	20,47	11,10	7,62	62,03	.3125-24	6,6	1,58	45,40	
05	7,937	8,31	22,96	11,10	9,14	47,63	.3125-24	6,6	1,58	30,15	
051	7,937	8,31	22,96	11,10	9,14	57,66	.3125-24	6,6	1,58	37,00	
052	7,937	8,31	22,96	11,10	9,14	57,66	.4375-20	9,4	2,36	37,00	
06	9,525	10,6	26,04	12,70	11,84	49,23	.3750-24	7,9	2,36	30,15	
061	9,525	10,6	26,04	12,70	11,84	61,52	.3750-24	7,9	2,36	42,00	
07	11,113	11,5	29,21	14,3	13,64	53,98	.4375-20	9,4	2,36	32,54	
08	12,700	13,1	33,96	15,9	15,42	61,93	.5000-20	11,07	2,36	37,29	
081	12,700	13,1	33,96	15,9	15,42	79,86	.5000-20	11,07	2,36	54,00	
10	15,875	14,7	38,74	19,1	18,97	66,68	.6250-18	13,74	3,18	39,68	
101	15,875	14,7	38,74	19,1	18,97	81,03	.6250-18	13,74	3,18	53,60	
12	19,050	16,3	45,09	22,2	21,46	73,03	.7500-16	16,84	3,18	42,85	
14	22,225	19,4	51,44	22,2	25,27	85,73	.8750-14	19,74	3,96	50,80	
16	25,400	25,8	70,49	34,9	32,23	104,78	1.2500-12	28,85	4,75	59,51	

Diameter Code	R	β	Starting Torque normal Code N	Starting Torque reduced Code X	Static Radial Limit Load	Static Axial Limit Load	Static Ultimate Load	Static Dynamic Load	Fatigue Load	Weight
	[mm]		[Nmm]	[Nmm]	[kN]	[kN]	[kN]	[kN]	[kN]	[g]
03	6,5	15°	0,06 to 0,56	0 to 0,11	20,0	7,9	30,0	21,8	3,3	33
04	6,5	15°	0,11 to 0,56	0 to 0,11	20,0	7,9	30,0	21,8	3,3	33
041	6,5	15°	0,11 to 0,56	0 to 0,11	20,0	7,9	30,0	21,8	3,3	41
05	6,5	14°	0,11 to 0,56	0 to 0,11	20,0	7,3	30,0	26,9	3,4	39
051	6,5	14°	0,11 to 0,56	0 to 0,11	20,0	7,3	30,0	26,9	3,4	43
052	6,5	14°	0,11 to 0,56	0 to 0,11	20,0	7,3	30,0	26,9	3,4	43
06	6,5	8°	0,11 to 0,56	0 to 0,11	29,1	11,7	43,6	37,0	4,8	62
061	6,5	8°	0,11 to 0,56	0 to 0,11	29,1	11,7	43,6	37,0	4,8	68
07	6,5	10°	0,11 to 0,56	0,03 to 0,15	31,4	14,4	47,1	52,3	6,1	83
08	6,5	9°	0,11 to 0,56	0,03 to 0,15	57,2	15,4	85,8	66,5	9,7	126
081	6,5	9°	0,11 to 0,56	0,03 to 0,15	57,2	15,4	85,8	66,5	9,7	141
10	6,5	12°	0,11 to 0,56	0,03 to 0,15	66,9	18,3	100,4	90,1	11,0	192
101	6,5	12°	0,11 to 0,56	0,03 to 0,15	66,9	18,3	100,4	90,1	11,0	212
12	8,0	13°	0,11 to 0,56	0,03 to 0,15	88,2	22,9	132,2	116,5	14,5	290
14	8,0	6°	0,23 to 0,90	0,04 to 0,25	102,8	27,1	154,2	149,4	17,0	437
16	8,0	12°	0,23 to 0,90	0,04 to 0,25	230,9	35,4	346,9	250,2	38,1	1150



Designation

EN6056 R 04 N T K

Longitudinal Groove

F: Without Groove

K: With Groove

Surface Treatment

T: Passivated

P: Cadmium Plated

Starting Torque

N: Normal

R: Reduced

Diameter Code

Thread

R: Right Hand

L: Left Hand

Number of EN Standard

Rod End: EN2539 / 17-4PH H1025 / 1.4548.4

Outer Ring: EN2539 / 17-4PH H1150 / 1.4548

Inner Ring: EN2030 / AISI 440C / 1.3544.9

Liner: per EN2755 / SAE AS81820

Technical Specification: EN2068

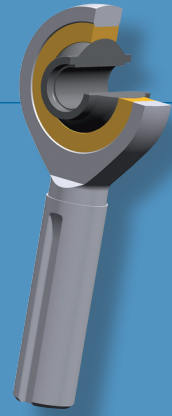

EN6056

- > Male Thread
- > Self Lubricating
- > CRES